

QCS

Toshiyuki OKI

on behalf of the SuperKEKB QCS Group

The 27th KEKB Accelerator Review Committee

2024/MAR/26th

Outline

- Main work carried out during LS1
 - (1) Modifications of the head of QCS cryostat to reduce background
 - (2) Repair of vacuum leakage at the QCSR service cryostat
- Operational status (cooling, magnet power supply)
- Plan for anti-ageing of old system
 - (1) Overhaul of electric motor for helium compressor
 - (2) Refrigeration control system renewal
- Considerations
 - (1) Additional heat exchanger
 - (2) Cooling margin of refrigerator

Modification work around IR to reduce background

- Before LS1, the beam background production points were evaluated by the Belle group.

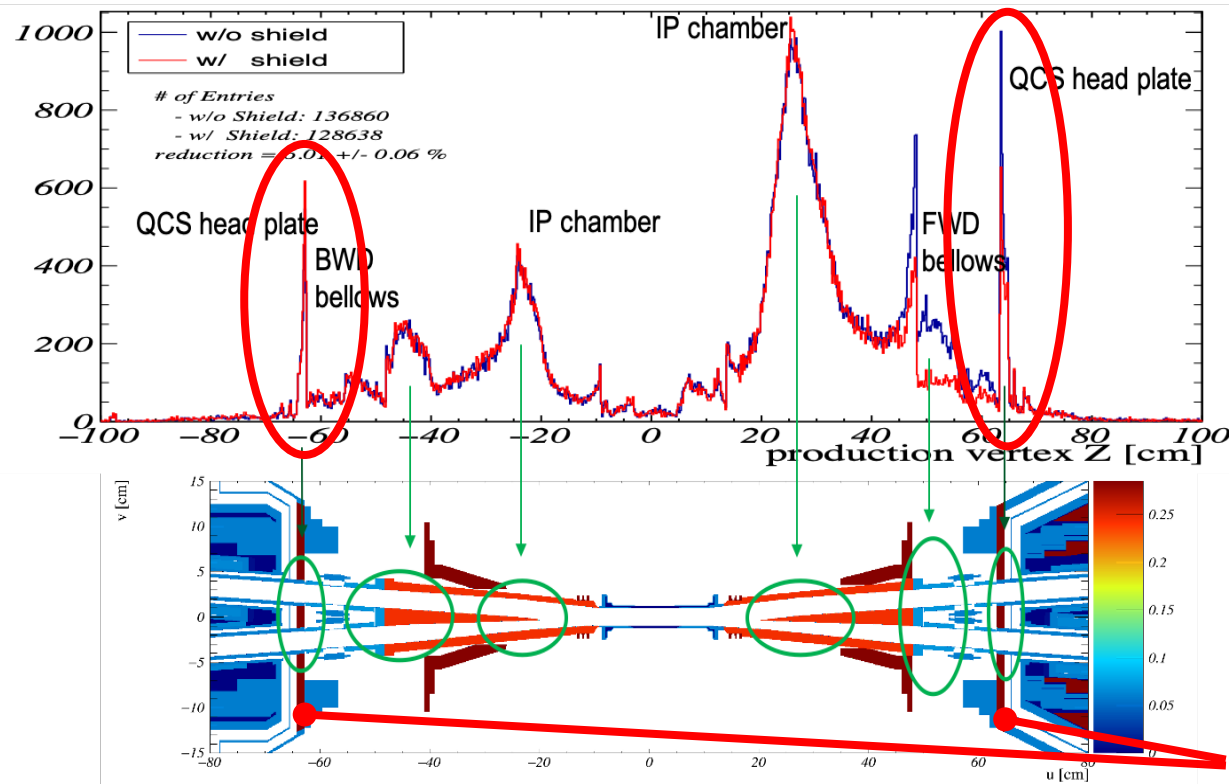

made by heavy metal

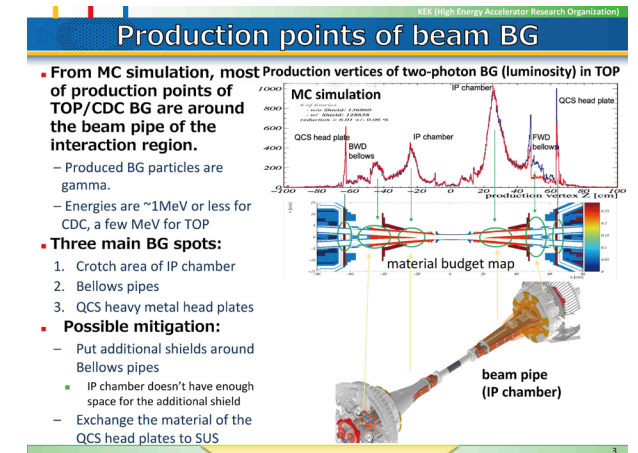

K. Nakamura. Mar 4, 2021
SuperKEKB IR meeting

- During LS1, modification work was carried out around the IR to reduce background: the Belle group added several types of shields, and we, QCS group, together with the vacuum group, modified the front part of the QCS cryostat.

QCSL cryostat: head plate replacement

- The tungsten head plate at the front part of the QCSL cryostat was replaced with a stainless steel one.
- For this replacement work, the beam pipes had to be shaken across the beam axis, so that the flanges between the cryostat and beam pipes were removed. In preparation for that, the cryostat front section was supported on a stand while the cryostat middle section was opened to allow access to the beam pipe support screws and BPM cables. Displacement measurements were carried out before and after the work.

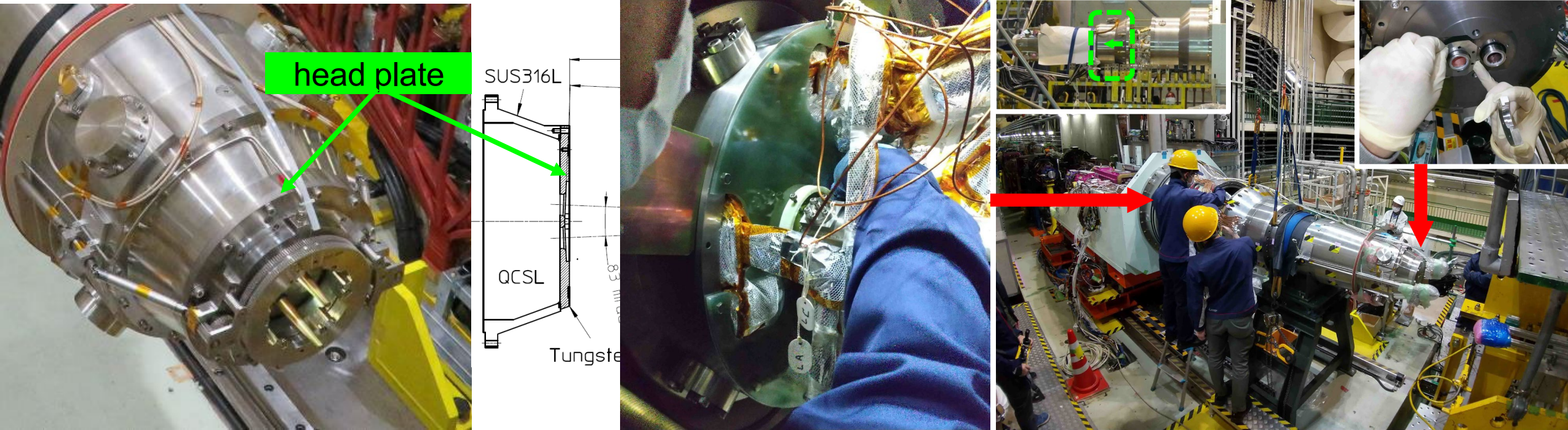

QCSR cryostat: front cap with head plate replacement

- For the QCSR, the tungsten head plate was also replaced with a stainless steel one.
- Furthermore, the front cap of the cryostat has been redesigned smaller along with the inner heat-insulating layers, so that the cable space for the VXD was enlarged.
- The QCSR cryostat has service ports from which the beam pipes can be accessed.

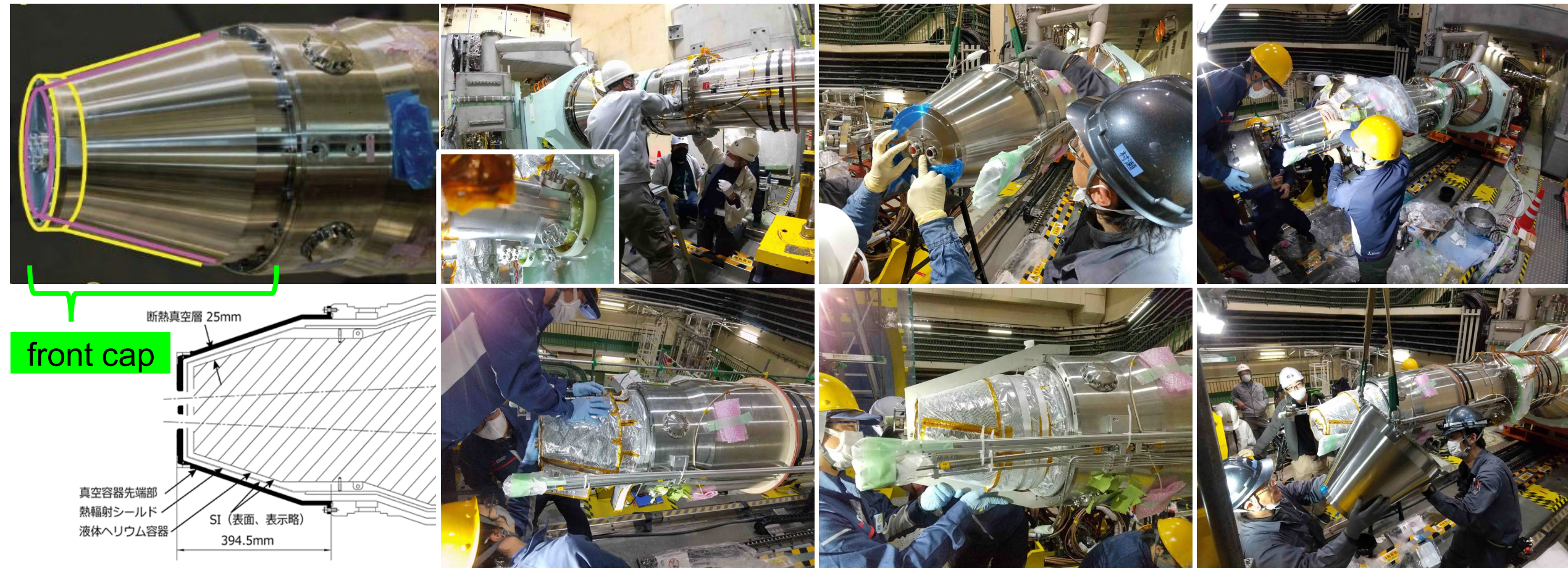

Vacuum leak repair work on the QCSR service cryostat

- Before LS1, a vacuum leak had been found in the upper and lower connection of the QCSR service cryostat.
- During LS1, it was investigated for identification of the leakage part and repaired.

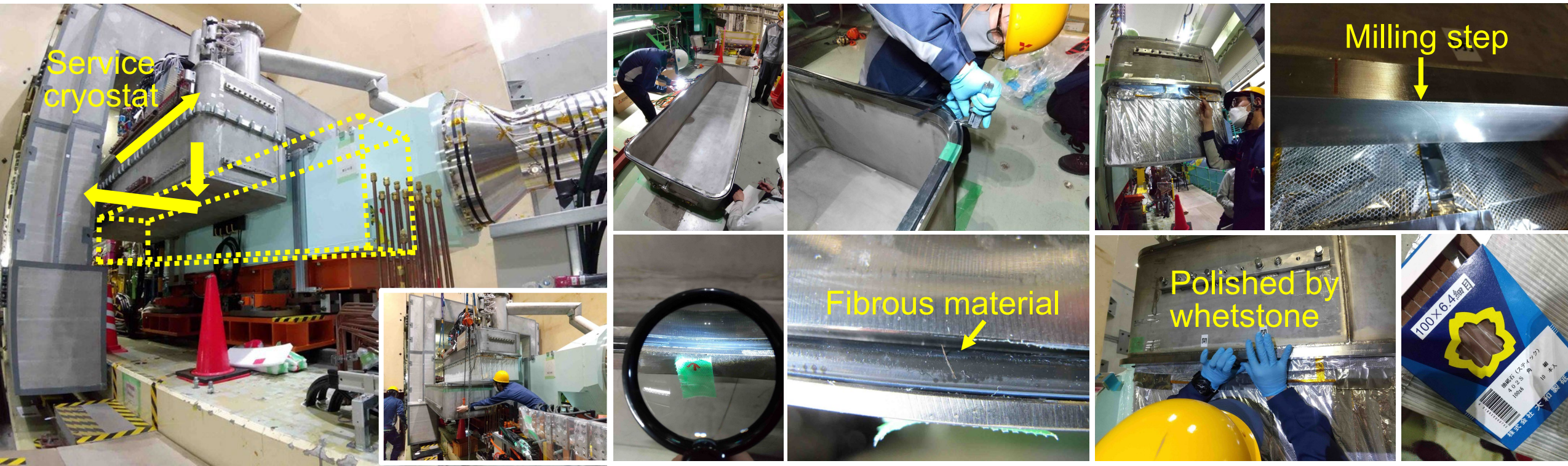

QCSR leak rate and vacuum pressure after repair

- The leakage rate of the QCSR cryostat was high before the repair work, but improved to the same level as the QCSL after the repair.
- A cooling test in December 2023 confirmed that the vacuum pressure could be reached at the same level as the QCSL both at room temperature and at low temperatures.

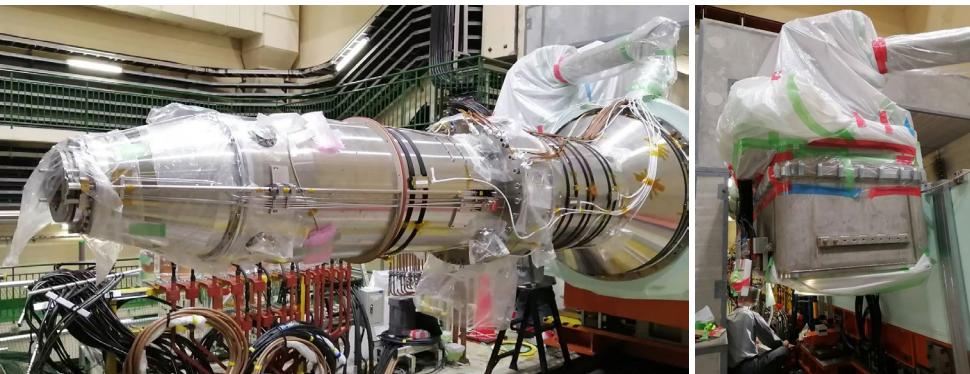
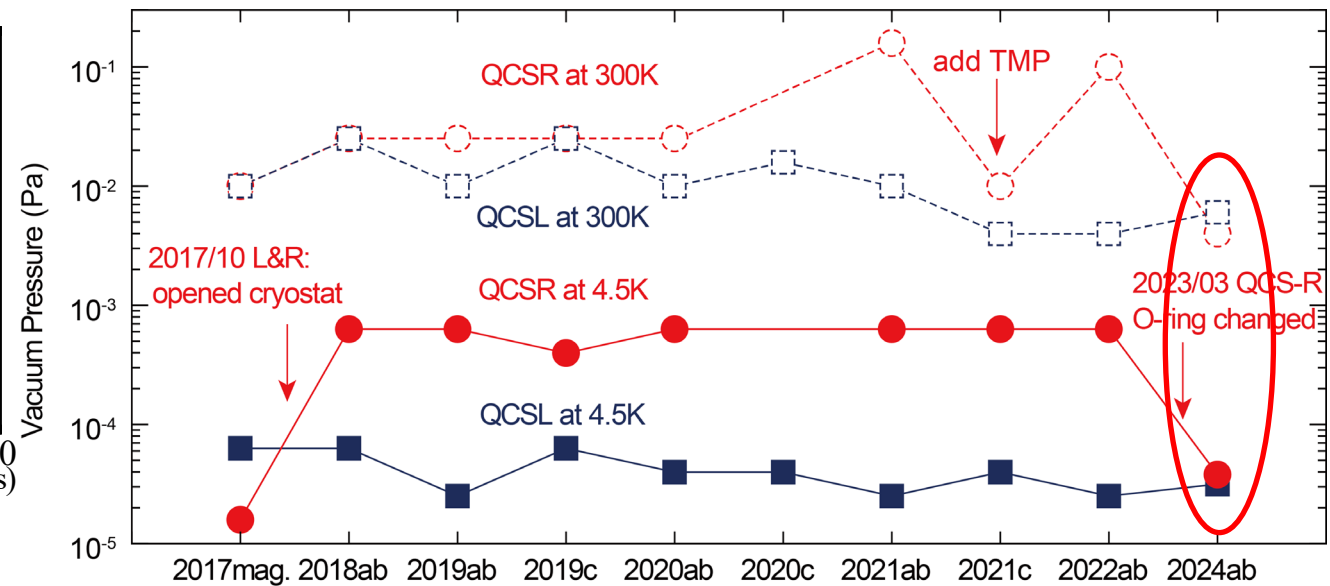
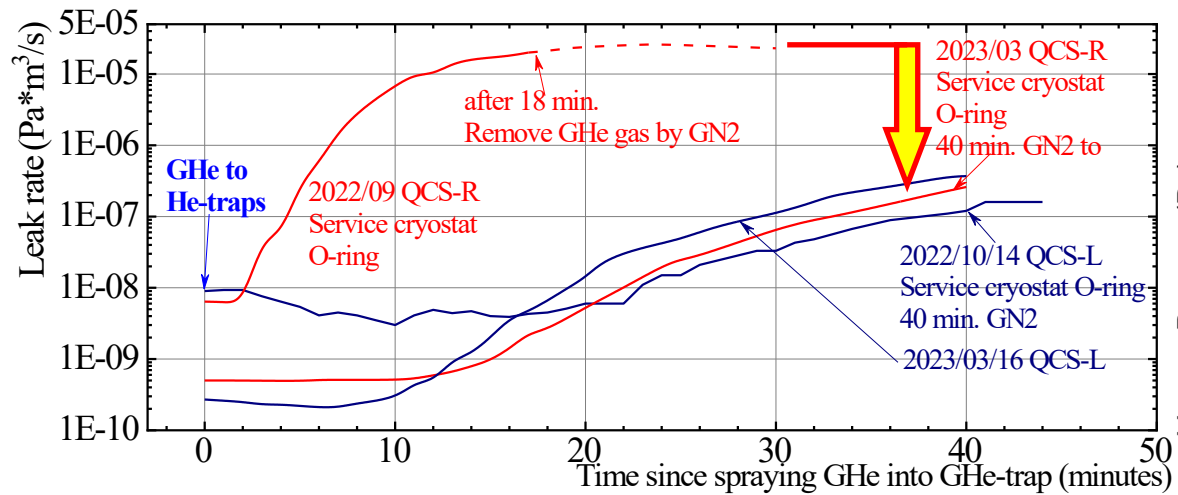

Current status of QCS: cooling

- According to the cooling characteristic curve at the start of cooling, the QCS has been cooled well without any negative effects due to the cryostat modification work during LS1.

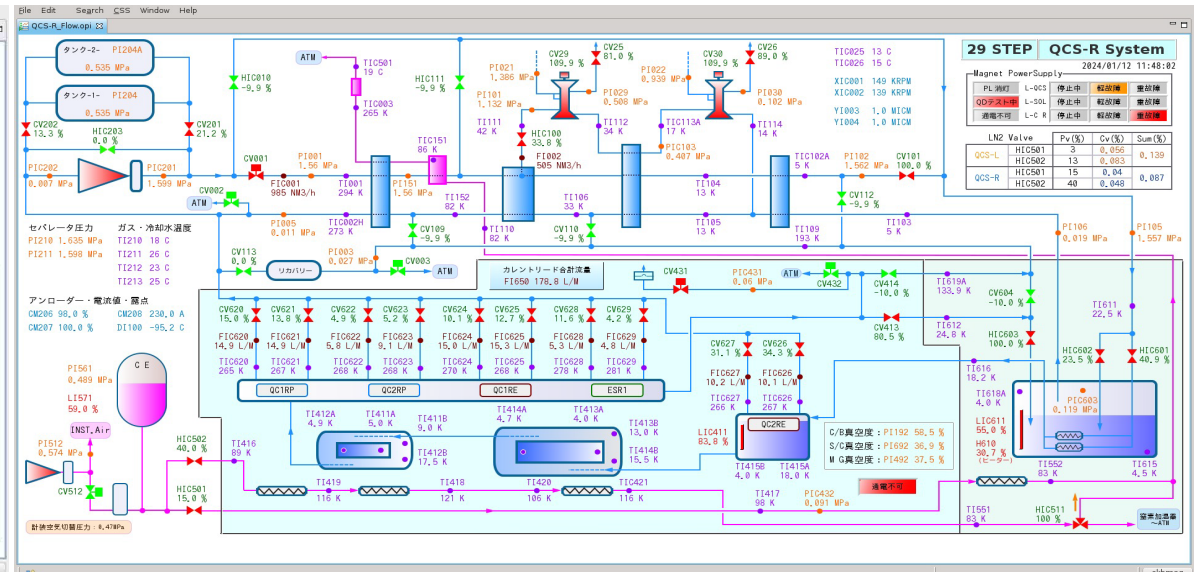
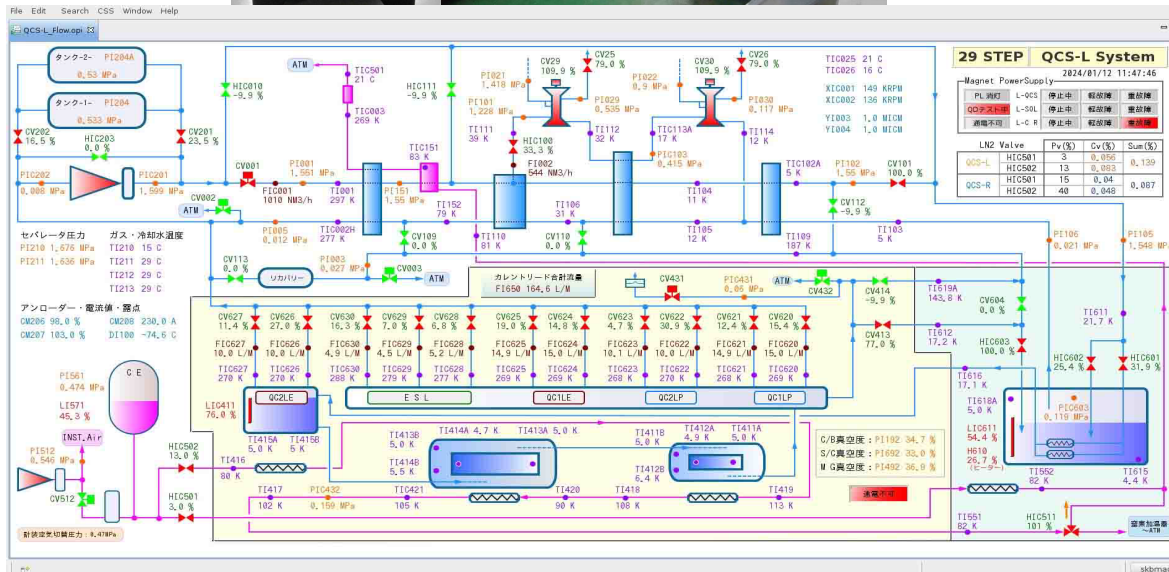
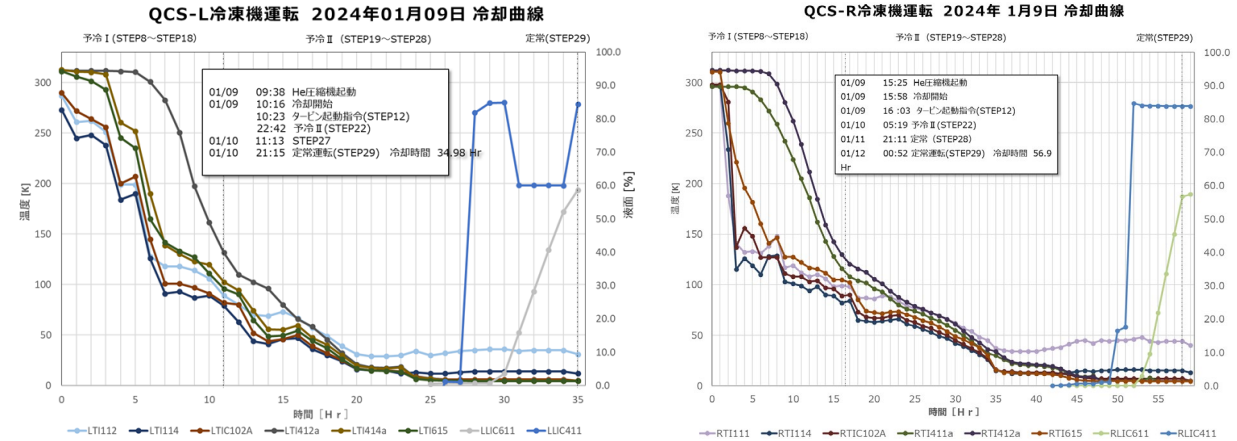

Current status of QCS: operation

- From the start of 2024a run to the present, the QCS magnet power supply has operated stably without failure with a current stability of a few ppm/week.
- As reported in the previous ARC, the QC1 magnet initialisation pattern for ramp-up is also used in 2024a run to mitigate the flux creep in superconducting magnets.

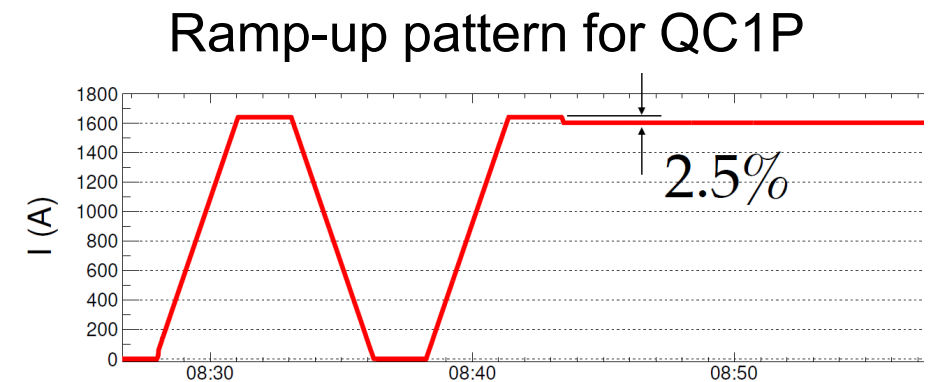
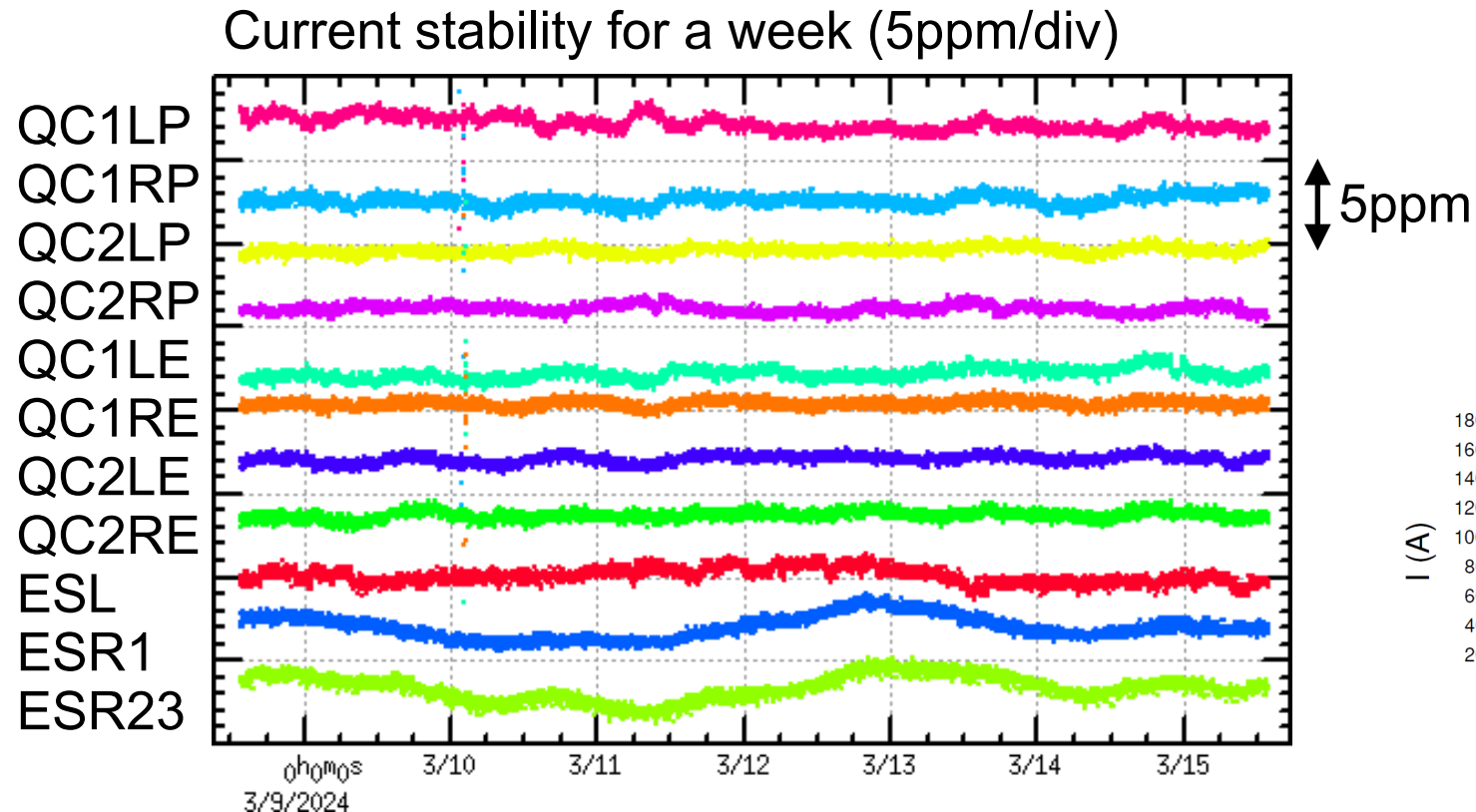

Overhaul/renewal of deteriorated system: motors for He compressor

- There are three electric motors for the helium compressor, one each for the QCSL/QCSR and one for a spare. These are over 30 years old and beyond their usual lifetime, so an overhaul is planned.
- To allow overhauls to be carried out during short shutdown periods, the plan is to overhaul the three motors in sequence, one each year; one was done last year and the other will be done this year.

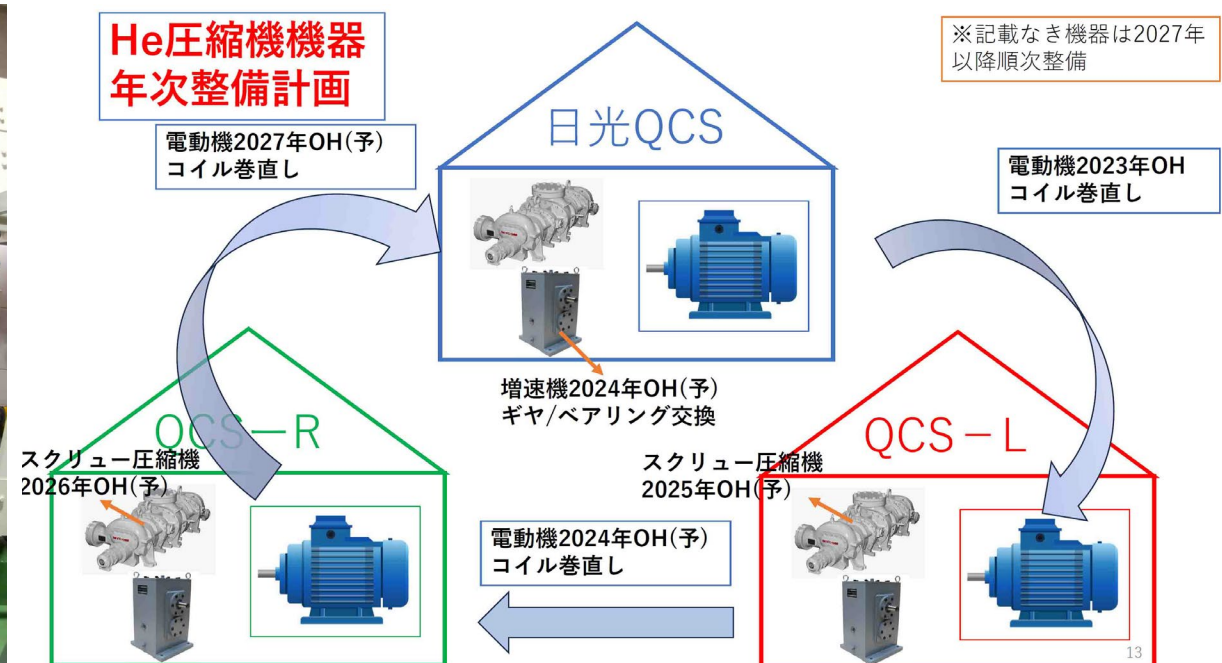

Overhaul work for the QCSL He compressor motor in 2023 (1/2)

- Overhaul of a motor for QCSL He compressor was carried out at a factory in 2023.
- An electrical test was carried out just before the overhaul work.
- The results showed that the worst-case remaining lifetime was only about one year. The need for overhaul for the remaining motors is strongly recognised.

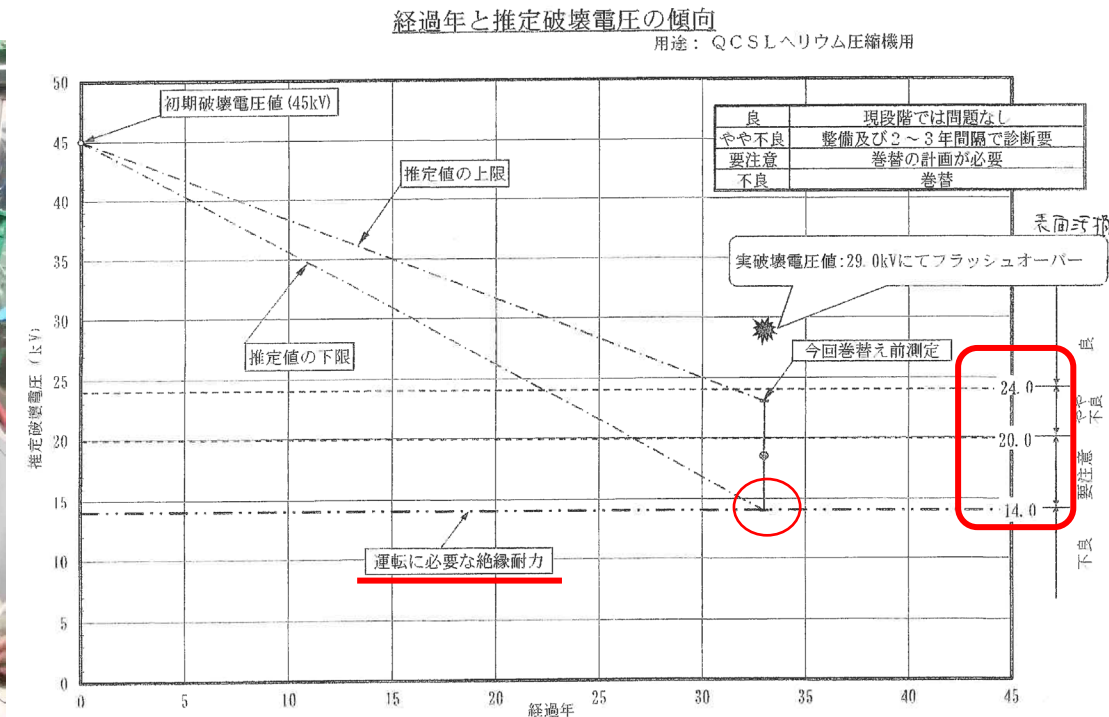

Overhaul work for the QCSL He compressor motor in 2023 (2/2)

- At the factory, the bearings were replaced, coils were rewound, and various adjustments and tests were carried out.
- The overhauled motor has been applied to the QCSL and is currently operating without problems. Overhaul for QCSR motor is planned in summer 2024.

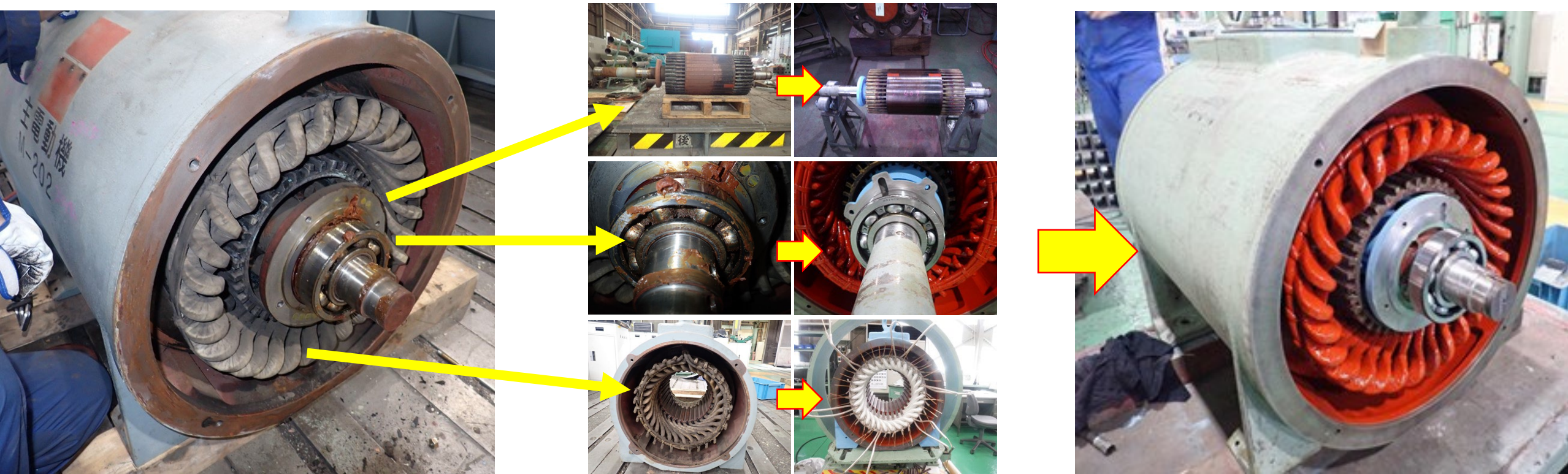

Overhaul/renewal of deteriorated system: refrigerator control system

- The control system controls the refrigerator from Nikko control room to Tsukuba area (consisting of more than 300 control loops).
- The system has been in use since the KEKB era and is no longer supported by the fabrication maker. Some of them have no replacement parts.
- The control system needs to be updated to operate for the next 10 years or so.
- The most important thing to keep in mind is not to destroy the existing refrigerator system (the refrigerator system cannot be replaced. It is too expensive and impractical to renew them.).

Nikko control room



Renewal Plan

- There are two main options for the update plan.
 - (A) Install successor system of the current system: All design (including sequence design) is done by the manufacturer.
 - (B) Build a new system by ourselves: All design is done by ourselves, where the system will be based on PLC. The cooling control scheme in the software is the same as the present system.



Current system



PLC based home-made system

Pros. & Cons.

	(A) Successor	(B) Home-made
Cost	790k USD (Belle+QCS)	Low (R&D cost is unknown)
Manpower	a few	Large
Compatibility (system, operation)	Good	Poor
Risk to destroy a refrigerator or stop system	Low	Need to debug with spare system

Coupled Belle & QCS system

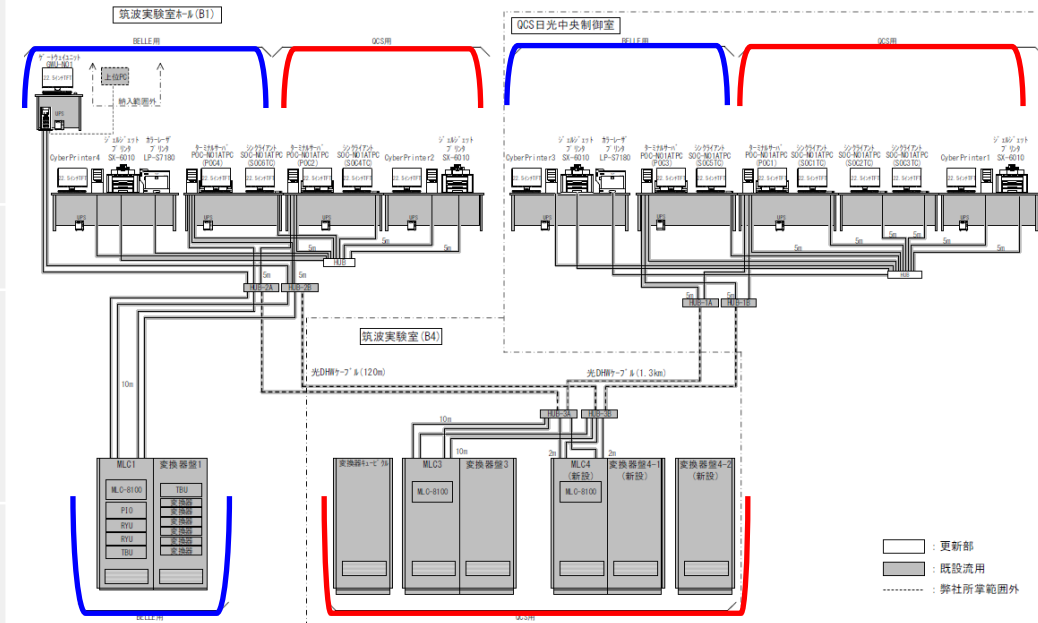

- Note: The QCS and Belle refrigeration control systems share information and infrastructure facilities with each other. It is therefore preferable to renew them at the same time in the same system. In particular, Belle's cryogenic group has commented that they want to avoid the uncertainty risk from the development required to introduce a new environment.

Reducing the use of LN₂: consideration of additional heat exchangers

- To reduce the LN₂ quantity consumed for the cryogenic system (**ECO-system**), we have started to discuss about the installation of the additional heat exchanger.
- The amount of the LN₂ quantity is 3500 L/day for the QCS-R and QCS-L helium cryogenic systems. The cost of the LN₂ per year is about 40 MJ¥ (267 kUS\$).
- By the additional heat exchanger, the amount of the LN₂ consumption can be reduced to be smaller than the half.
- For the installation, the cost is estimated to be 17 MJ¥ × 2 units. The work period in the practical setting is about 2 months (and for construction of the heat exchanger, 9 months).
- There is no risk for the additional heat exchanger, and the exchanger enhance the stability of the helium refrigerator.

Reducing the use of LN₂: Thermal condition of QCS cryogenic system

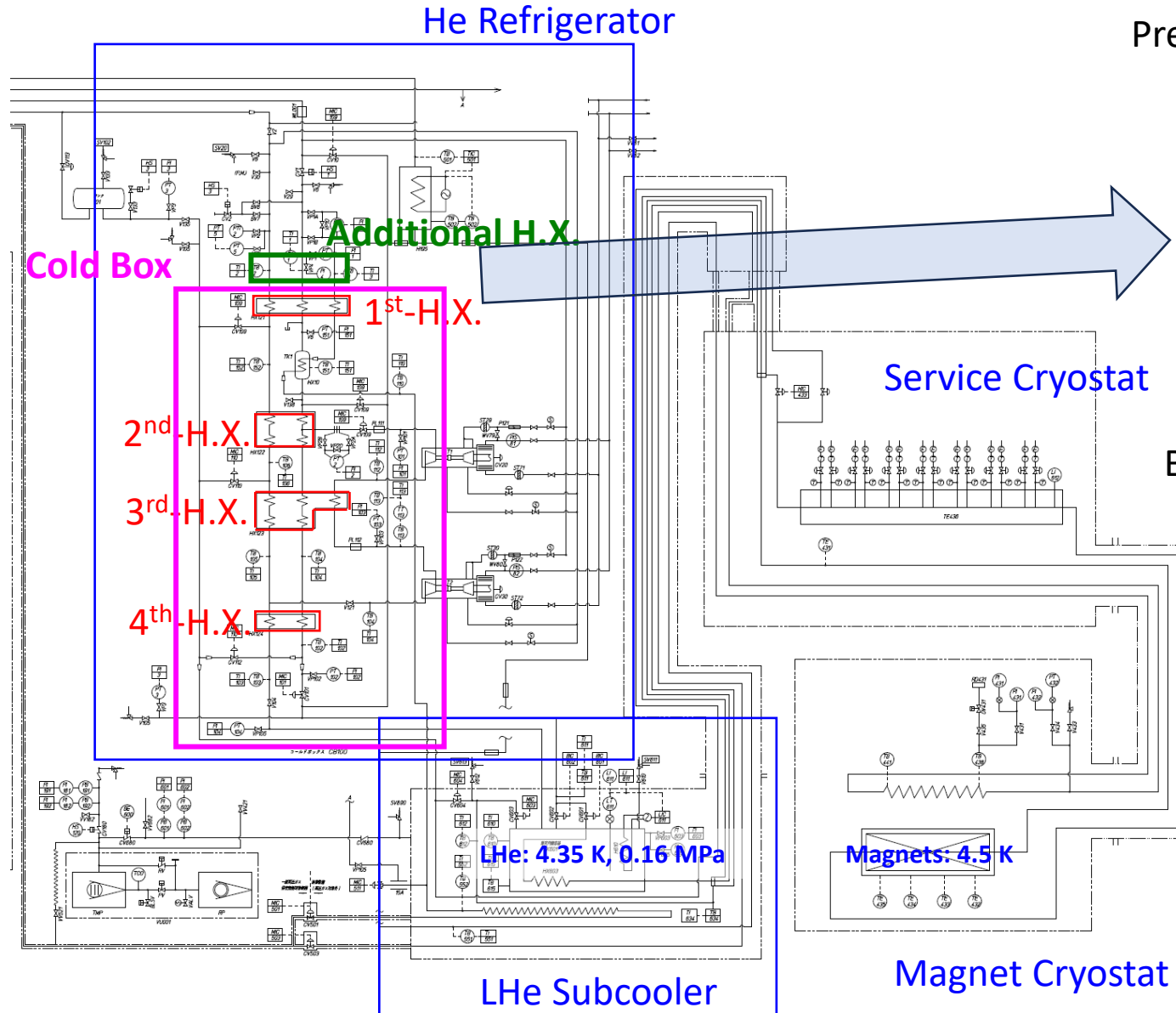

Present thermal condition at the 1st H.X.

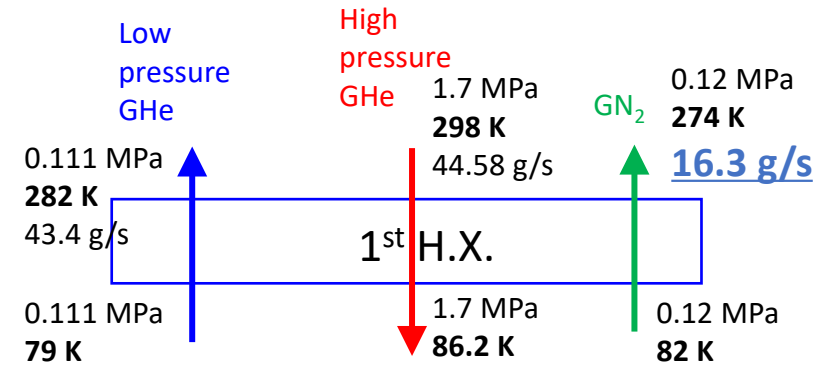

By adding the Heat Exchanger,

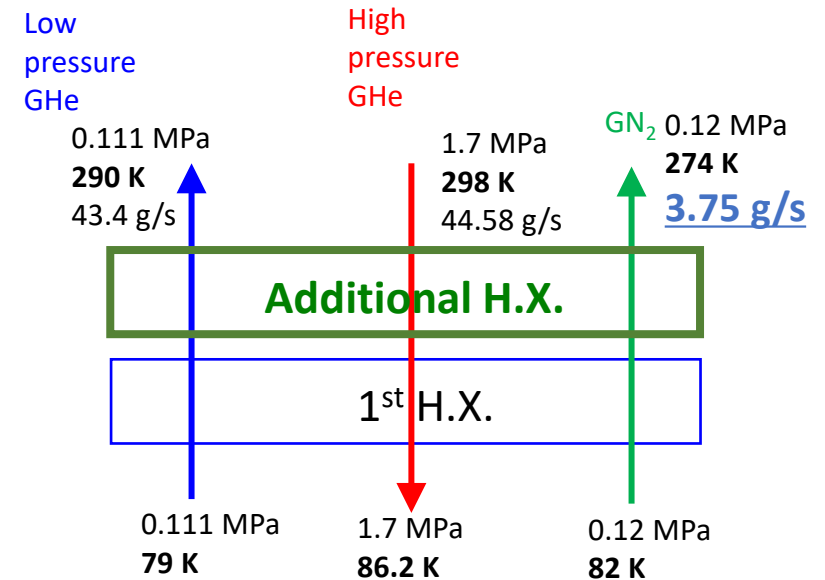

Reducing the use of LN₂: Thermal condition of QCS cryogenic system

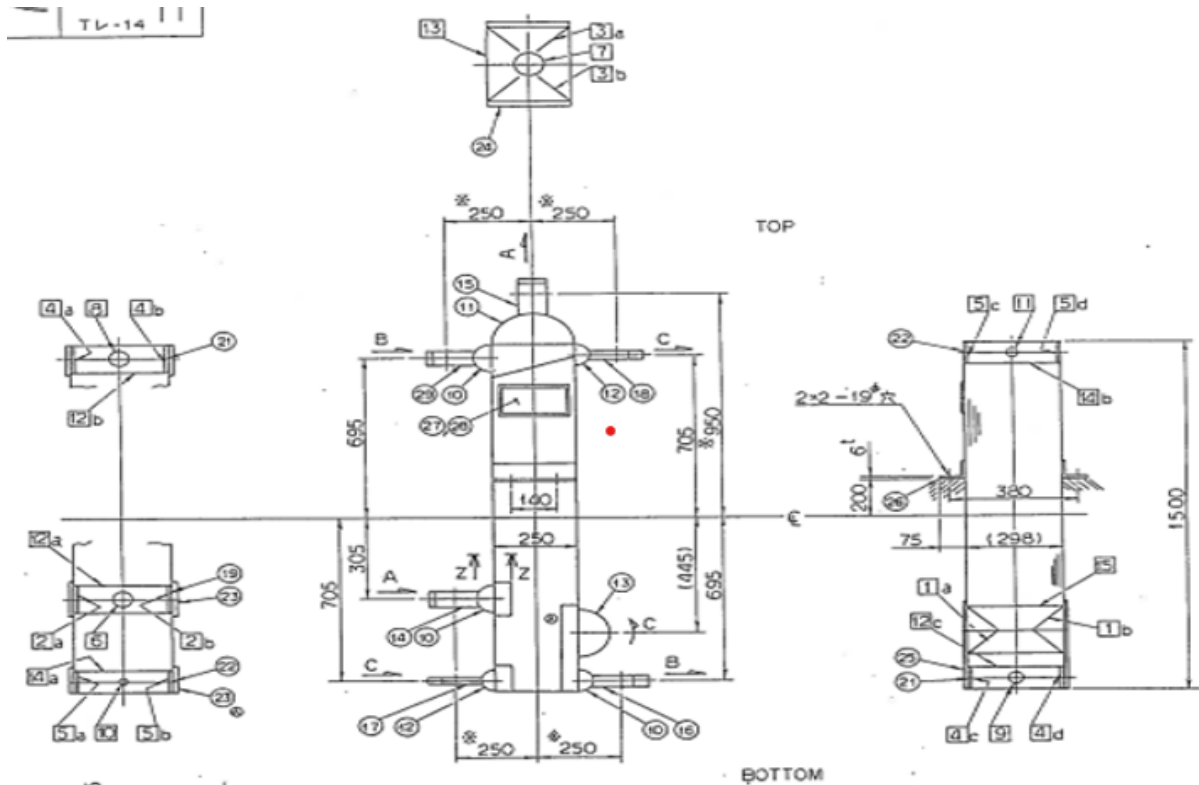

1st Heat Exchanger between high and low-pressure helium gases and nitrogen gas .
The additional heat exchanger is expected to be one third of the 1st H.X..

Location of the additional heat exchanger



QCS-R Helium refrigerator and sub-cooler

Cooling-power margin of the refrigerators

- We have begun to investigate the margin of cooling capacity in preparation for future upgrade plans.
- How to estimate current cooling-power margin:
 - The liquid level in the receiver is controlled to prevent liquid helium from overflowing by using a heater to evaporate the extra helium produced.
 - Heater power is as the refrigerator power margin.

$$P_{\text{heater}} = P_{\text{margin}}$$

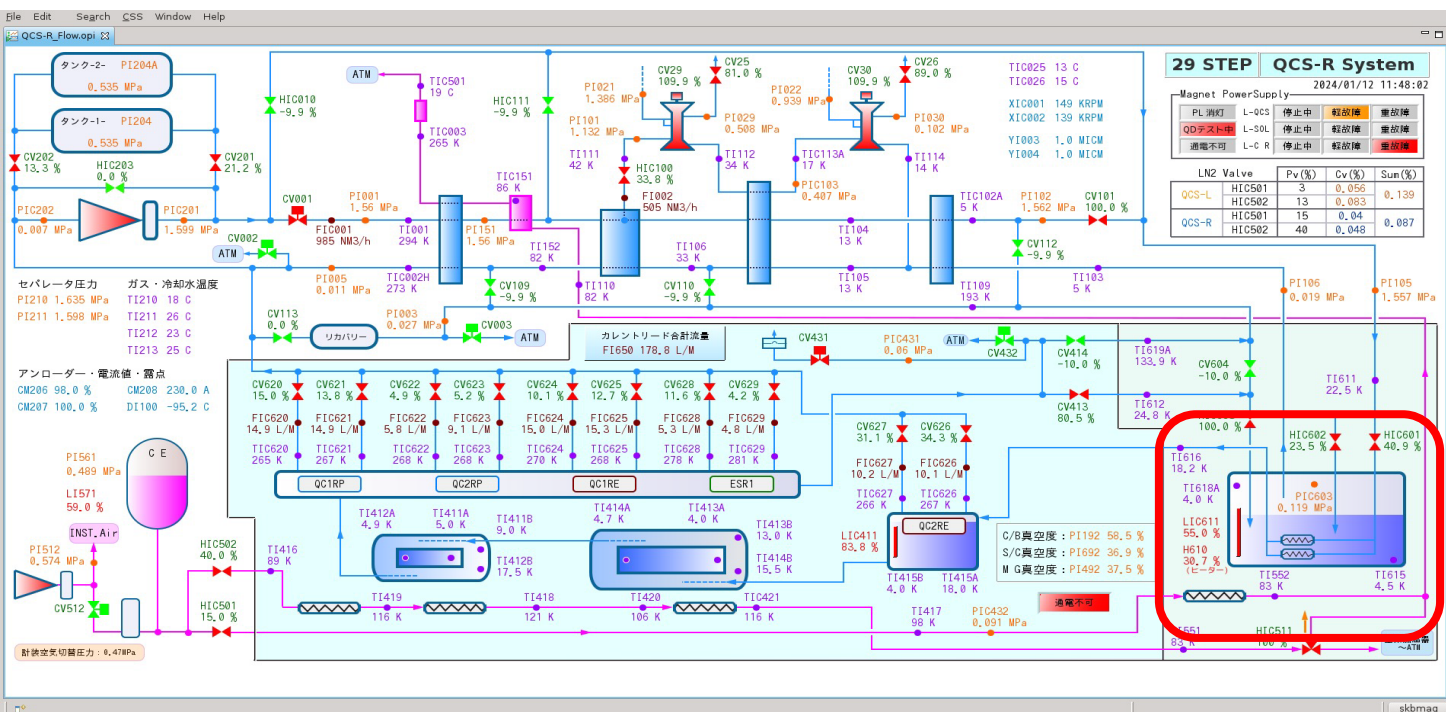

Liquid Helium from Liquefier to Magnets

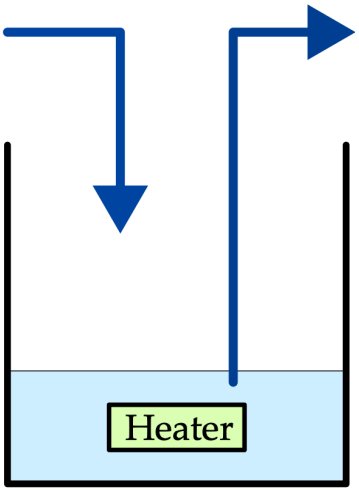

Decrease heater power

Liquid Helium from Liquefier to Magnets

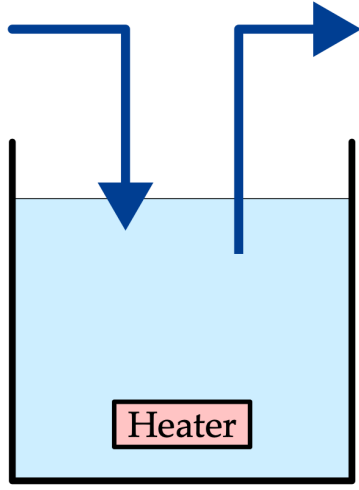

Increase heater power

History of the heater power of QCSR (margin of the refrigerator)

- The heater power varied and exhibited 0 watt, sometimes. The variation caused by change of operation conditions such as the liquid nitrogen filling. A heater power of 0 W indicates that the heat load exceeds the liquid helium supply.
- Even if the control is well adjusted and the heater power can be smoothed, the margin is only ~20 W for a cooling power of 250 W.
- We need careful consideration to maintain the margin of the cooling power.

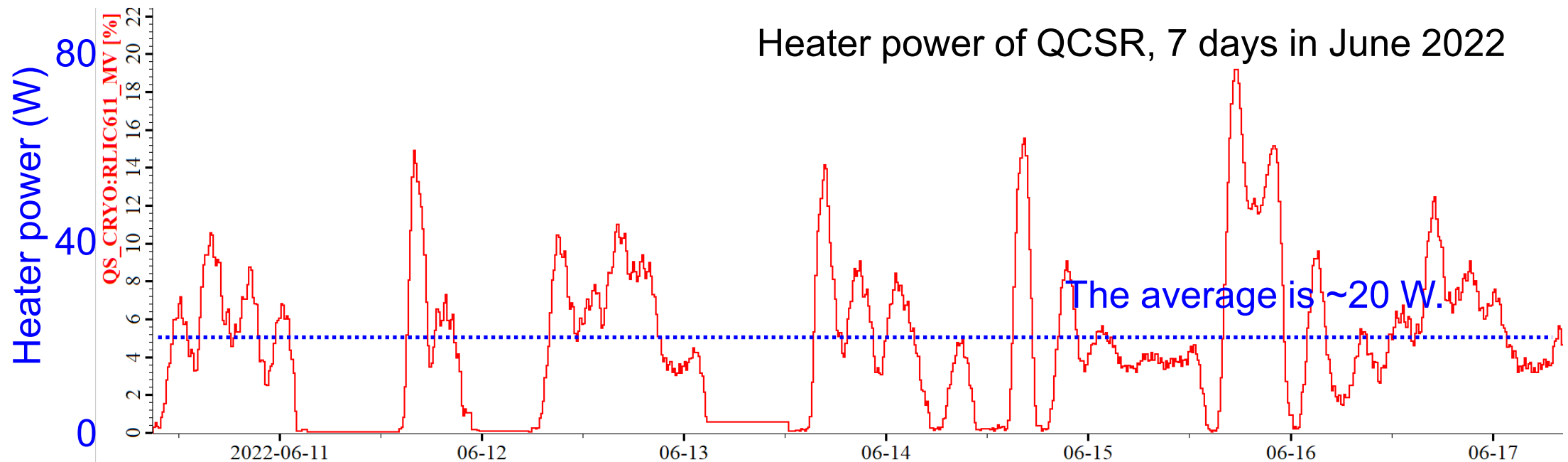

Summary

- During LS1, the head of QCSL/QCSR cryostats were modified to reduce background. Vacuum leakage at the QCSR service cryostat was also repaired.
- QCS magnet power supply and cooling system have operated stably from the start of 2024a run to the present.
- Plans to overhaul or update ageing systems: electric motors for helium compressors are planned to be overhauled annually. Consideration has started to be given to renewing the refrigeration control system.
- Consideration for the additional heat exchangers to reduce liquid nitrogen and the cooling margin of refrigerator has begun.

Backup

Control systems and operations of cryogenic systems

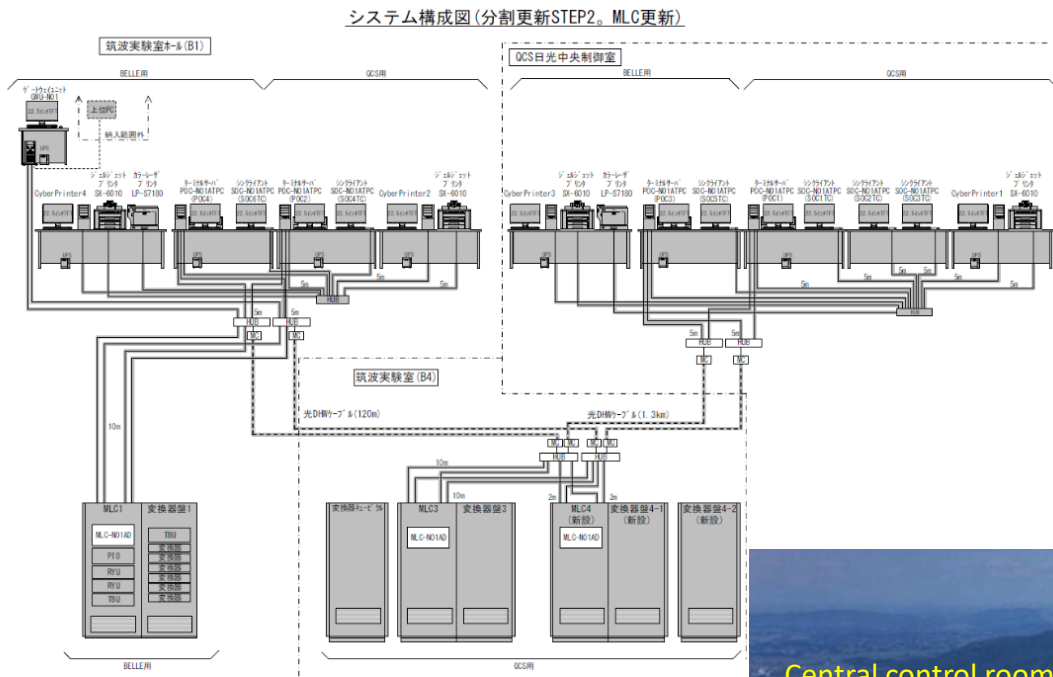

Operations (QCS-L&R+BelleII):

- KEK staffs: on-call
- 3 operators/shift, 3 shifts/day
- Same control room in the Nikko Hall with cryogenic system of SuperKEKB SRF cavities, STF and cERL.

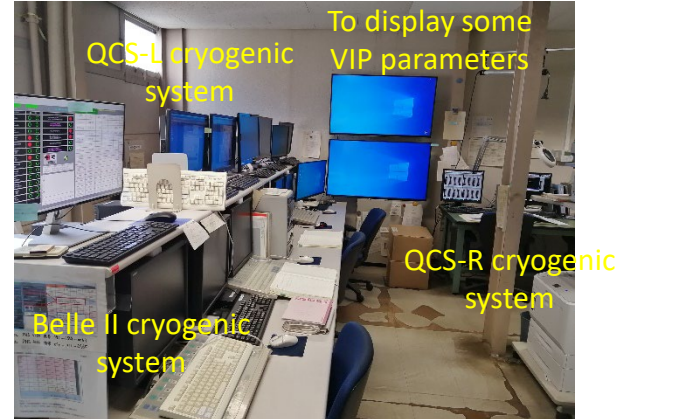
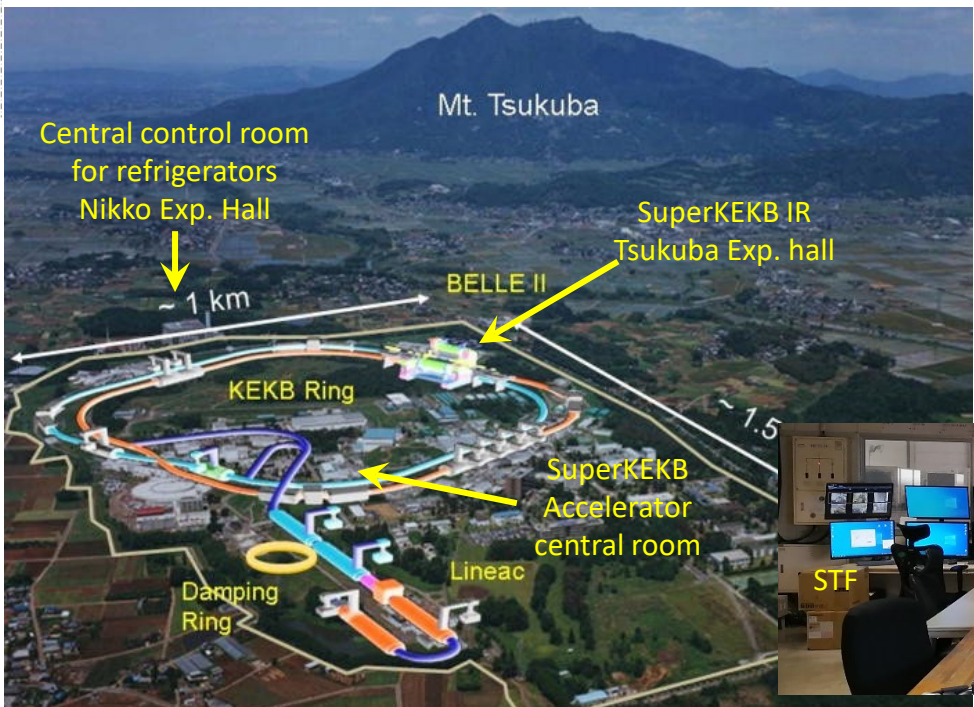

QCS systems of SC magnets, cryostats and cryogenic systems

Subcooled cooling scheme (stable, temperatures lower than saturated LHe)

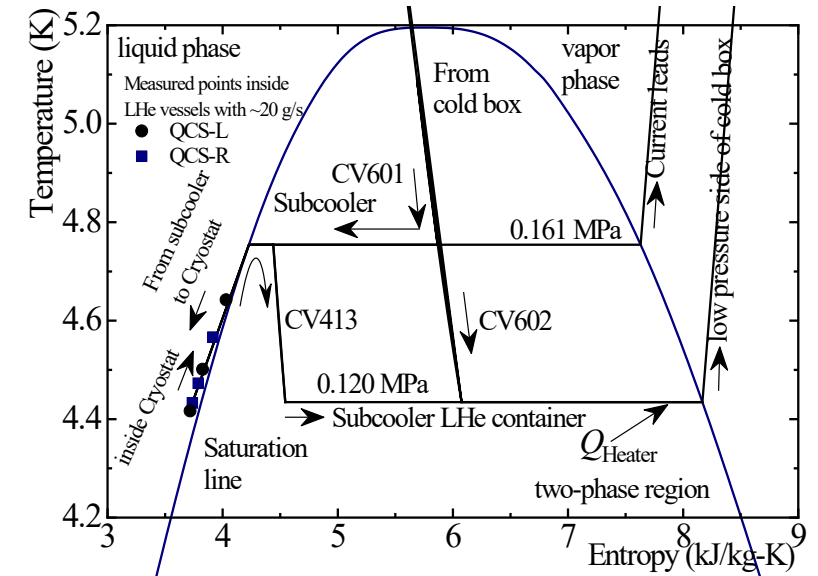
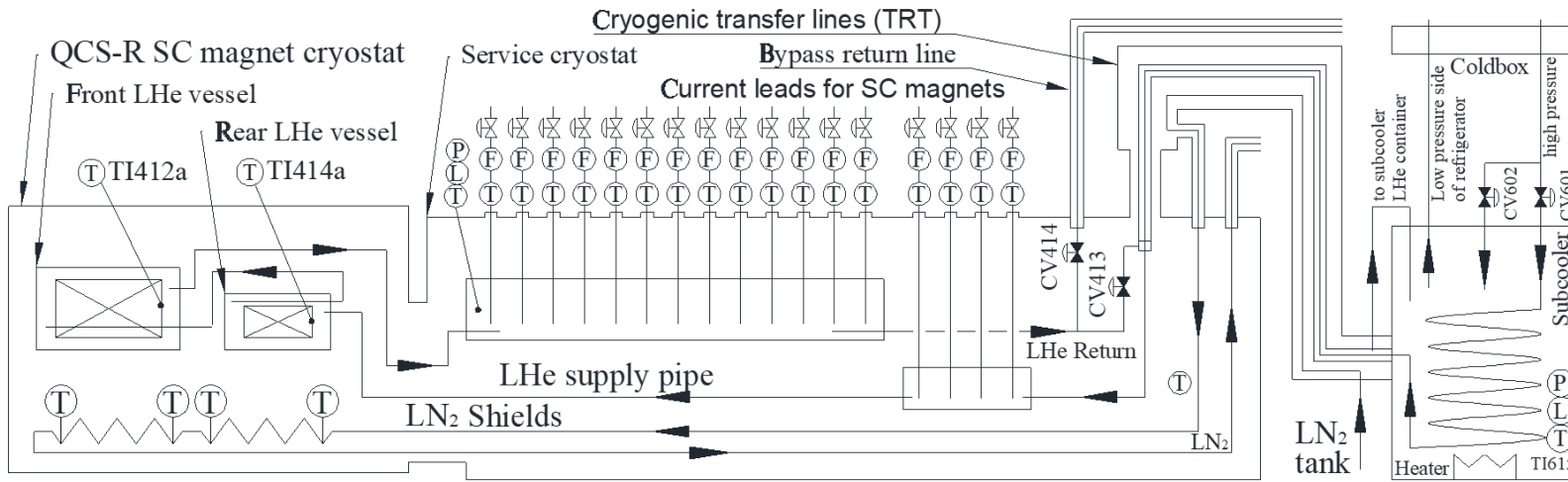

Mixed loads of refrigeration and liquefaction (250 W in total, to cool 51 leads in QCS-L and 59 in QCS-R, 40 L/hour)

- Total operation time: ~ 30 khours
- QCS quench events: 66 (48 due to beams), recently due to earthquake

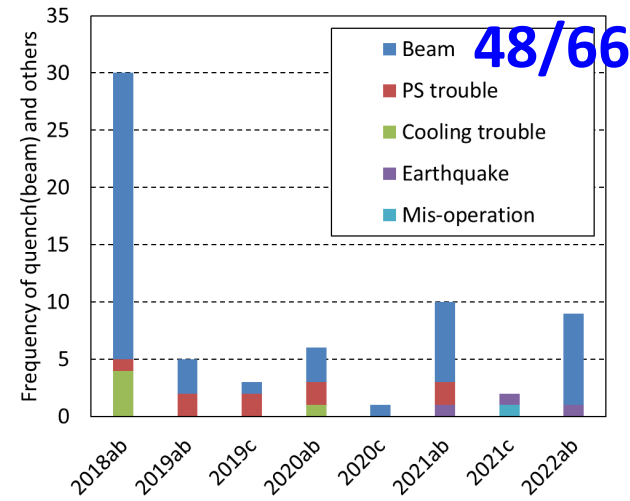
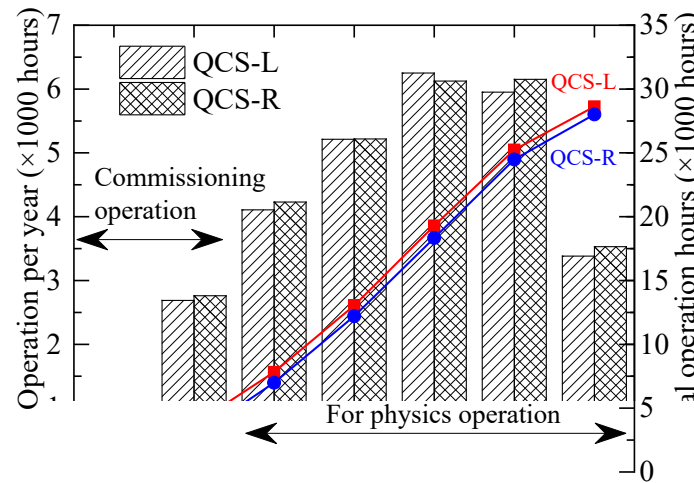
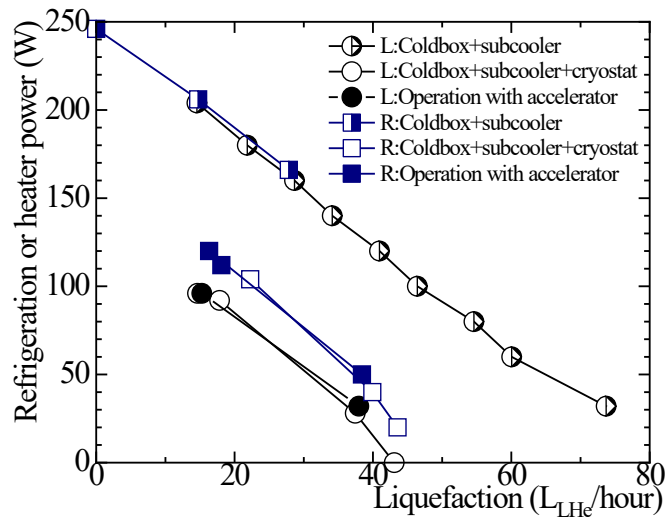

QCS systems of SC magnets, cryostats and cryogenic systems

Ground devices (compressors, helium tanks, liquid nitrogen tanks)



Underground devices (refrigerators, subcoolers, cryostats, instrumentations and quench detectors)

